

GEAR BOX

TREUILS

ARGANI

Gear box type MR12 (50/60Hz) - Static load kg 2500

Treuil MR12 (50/60Hz)- Charge statique kg 2500

Argano MR12 (50/60Hz) - Carico statico kg 2500

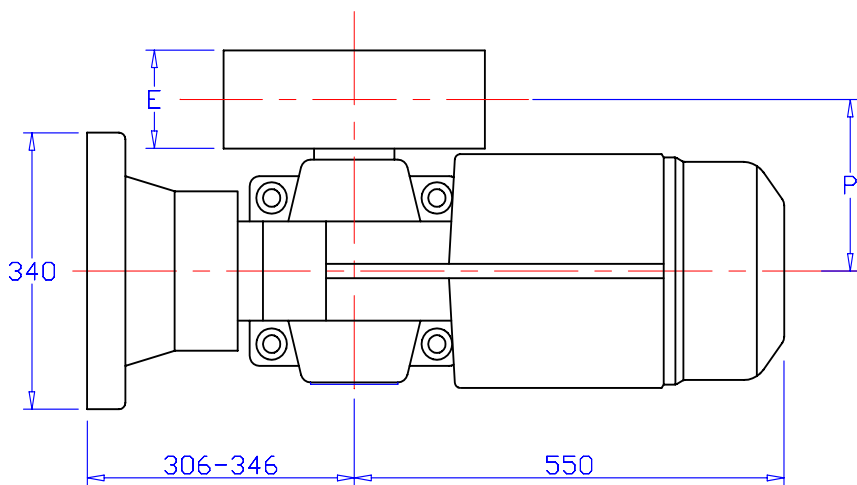
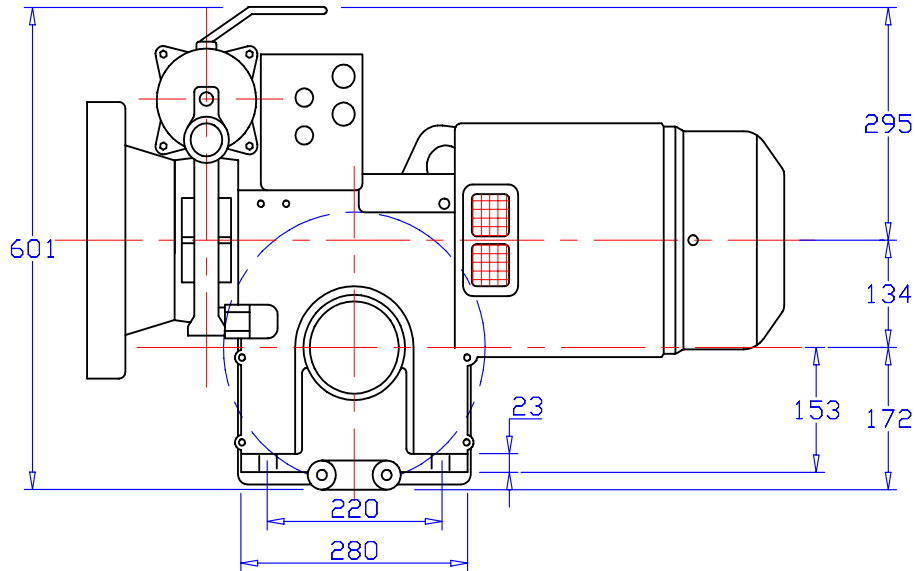

Olio per carter
Casing oil
Huile pour carter
Gehanse-Oil

Esso spartan EP 220
Shell omala oil 220
Mobil Mobilgear 630

Cambio olio ogni
Oil change every
Vidange d'huile toutes les
Öl Wechsel je de

12-18

mesi
months
mois
Monaten

Elettromagnete da
* d.c. electromagnet
Electro-aimant de
El. magnet von bis/gleichstrom

60 Vcc*

Capacità carter
Casing capacity
Capacité carter
Gehäusekapazität

3,5 l.

Peso argano con motore e puleggia
Winch weight with motor and pulley
Poids treuil avec moteur et poulie
Getriebegewicht mit Motor und Treibscheibe

Con volano
With flyweel
Avec volant
Mit Handrad

MAX 255 Kg